

## General Purpose Flanged Solenoid Valves S1070 / S1080 Series

### GENERAL FEATURES

- New design
- Full orifice flanged solenoid valves
- 3", 4", 6" and 8" connection
- TORK series S1070 (N.C) and S1080 (N.C) diaphragm solenoid valves are 2/2 way normally closed and pilot operated
- Suitable for water.
- Working Temperature: -10°C / +80°C
- Not suitable for use with dangerous fluids listed in Group 1
- Minimum operating differential pressure 1 and 1,5 bar
- High reliability, quality and performance; long life. corrosion resistance
- Wide pressure ratings, range of flow rate and orifice options
- Coils interchangeable
- Flow factor Kv of each valve is indicated, so that the flow Q can be calculated as a function of pressure
- Solenoid valves must be used with filtered fluids.
- Solenoid valve can be mounted in any position without affecting operation; vertical with coil upwards preferred.
- Standard pipe connection is G (BSP) (ISO 228-1) and on request; other pipe connections are available (NPT (ANSI 1.20.3))

### ELECTRICAL CHARACTERISTICS

Continuous Duty	: ED %100
Coil Insulation Class	: H (180°C)
Coil Impregnation	: Polyester Fiber Glass
Coil Encapsulation Material	: Fiber Glass Reinforced
Ambient Temperature	: from -10°C, +60°C
Protection Degree	: IP65 (ISO 60529) with coil duly fitted with the plug connector
Electric Plug Connection	: DIN 46340 3 - Poles Connector (DIN43650)
Connector Specification	: ISO 4400 / EN 175301-803 Form A, Spade Plug (Cable Ø6-8 mm)
Electrical Safety	: IEC 335
Standard Voltages	: For AC 12V, 24V, 48V, 110V, 230V For DC 12V, 24V, 48V, 110 V

On request other voltages  
 Voltages Tolerance : For AC -15%; +10%, For DC -5%; +10%  
 Frequency : 50 Hz, other frequencies on request; (60 Hz ...)  
 On request; connector with LED  
 Specify coil volt age with order

### MATERIALS IN CONTACT WITH FLUID

Body : Cast Iron

### SOLENOID MATERIALS

Internal Parts	: Stainless Steel, Brass
Sealing	: NBR
Shading Ring	: Copper (EN 12735-1)
Seats	: Brass
Core Tube	: Stainless Steel
Springs	: Stainless Steel

### OPTIONS

- Female connection: BSP; (On request NPT)
- On request CR-Ni plated, PTFE coated done
- On request Atex (exproof) coil.

### TECHNICAL FEATURES

Max. Viscosity : 5°E (-37cST veya mm²/s)  
 Response Time :  
 Opening time : 400 ms- 1600 ms  
 Closing Time : 1000 ms- 2000 ms

Solenoid Valve Symbol	Valve Type/ Order No	Connection Size	Pressure min/max		Kv	Fluid Temperature		Seal	Weight
			Bar	Bar		°C			
	S1070 / S1080	DN	Bar	Bar	l/min	min	max		kg
	S1070.10	80	1	6	3380	-10	80	NBR	20.7
	S1070.12	100	1	6	3610	-10	80	NBR	22.3
	S1070.18	150	1	6	7450	-10	80	NBR	54.2
	S1070.20	200	1	6	14600	-10	80	NBR	84.9
	S1080.10	80	1.5	16	3380	-10	80	NBR	20.7
	S1080.12	100	1.5	16	3610	-10	80	NBR	22.3
	S1080.18	150	1.5	16	7450	-10	80	NBR	54.2
	S1080.20	200	1.5	16	14600	-10	80	NBR	84.9

NORMALLY CLOSED

2/2 WAY

PILOT OPERATED

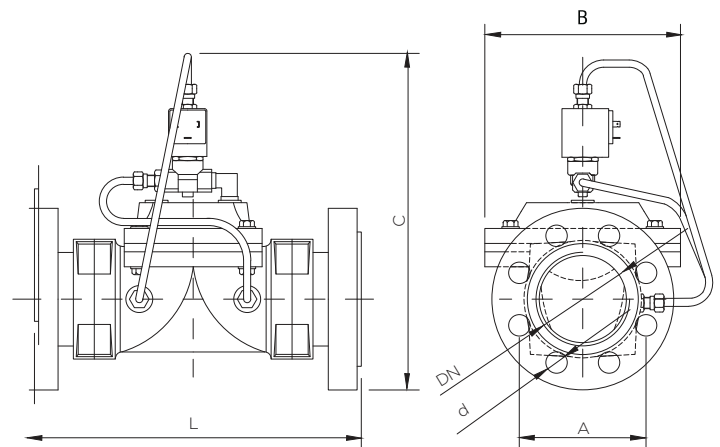

DN	L	C	B	A	d
80	300	340	208	160	18
100	305	365	208	180	18
150	390	450	300	240	22
200	475	550	385	295	22