

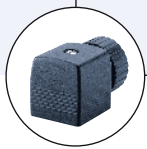

3/2-way Solenoid Valve for compressed air and vacuum applications

- 3-way solenoid valve with manual override
- Smoothly operating servo-piston
- For technical vacuum
- For neutral gases with low pressures
- NC or NO circuit function

Type 0344 can be combined with...



Type 2508

Cable plug



Type 1078

Timer unit

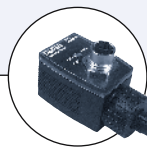

Type 2511

ASI cable plug

The pilot-controlled 3/2-way valve Type 0344 with a smoothly operating servo-piston requires a differential pressure of 0.25 bar for complete opening and closing. In the circuit functions NC and NO, it is particularly suited for use with neutral gases with low pressures and for technical vacuum, even with dry running.

Circuit function C

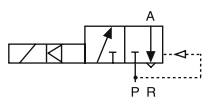

3/2-way valve NC

Circuit function D

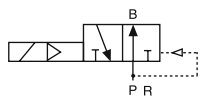

3/2-way valve NO

vacuum pump connected at port R

Technical data

Orifice	DN 8.0 - 40 mm
Body material	Brass
Coil material	Epoxy
Coil insulation class	H
Seal material	NBR
Media	Neutral gases, compressed air, vacuum
Media temperature	0 to +90 °C
Ambient temperature	Max. +55 °C
Voltage tolerance	±10 %
Duty cycle	100% continuous operation
Electrical connection	Cable plug for Ø 7 mm cable, acc. to DIN EN 175301-803 Form A (supplied as standard)
Protection class	IP 65 with cable plug
Installation	As required, preferably with actuator upright

Flow rate QN value air [l/min]	measured at +20°C, 1 bar pressure at valve inlet and free outlet
Pressure values [bar]	gauge pressures with respect to the prevailing atmospheric pressure
Response times [ms] Opening Closing	measured with water at valve outlet at 6 bar and +20°C pressure build-up 0 to 90% pressure decay 100 to 10%

* cable plug Type 2508 (supplied as standard) acc. to DIN EN 175 301-803, Form A

Technical data

Orifice [mm]	Qn value air P→A [l/min]	Port connection A/B und P	Pressure range [bar]	Power consumption				Response times		Weight [kg]
				Inrush AC [VA]	Hold AC (hot coil) [VA]	[W]	Hot/cold coil DC [W]	Opening [ms]	Closing [ms]	
8	1030	G 1/4	Vacuum	30	15	8	8/11	25	25	1.0
12	2800	G 1/2	up to	30	15	8	8/11	30	30	1.2
20	7200	G 3/4	3 bar	30	15	8	8/11	40	40	2.2
25	11000	G 1		30	15	8	8/11	70	70	2.7
40	26000	G 1 1/2		30	15	8	8/11	120	120	6.8

Materials

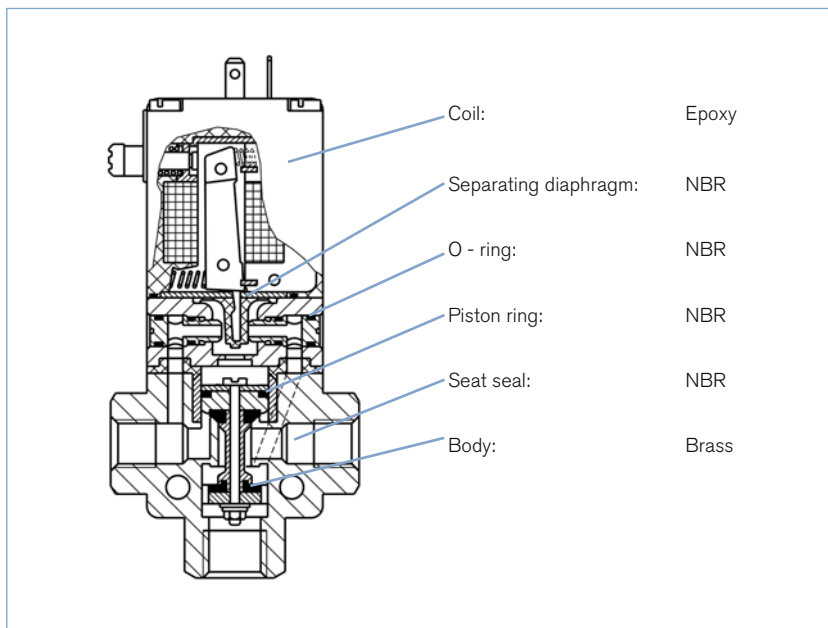

Ordering chart for valves (other versions on request)

All valves with manual override, brass body, NBR seal and cable plug

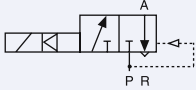
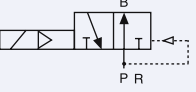
Circuit function	Port connection	Orifice [mm]	Q_{th} value air $P \rightarrow A$ [l/min]	Pressure range [bar]	Item no. per voltage/frequency [V/Hz]		
					024/DC	024/50	230/50
C 3/2-way valve NC 	G 1/4	8.0	1030	Vacuum up to 3	047 383	047 787	045 134
	G 1/2	12	2800	Vacuum up to 3	046 580	047 897	046 180
	G 3/4	20	7200	Vacuum up to 3	046 833	053 492	046 461
	G 1	25	11000	Vacuum up to 3	043 691	050 367	055 445
	G 1 1/2	40	26000	Vacuum up to 3	057 829	–	047 853
D 3/2-way valve NO 	G 1/4	8.0	1030	Vacuum up to 3	046 986	049 336	046 408
	G 1/2	12	2800	Vacuum up to 3	046 246	051 354	046 373
	G 3/4	20	7200	Vacuum up to 3	046 087	057 636	047 616
	G 1	25	11000	Vacuum up to 3	047 873	043 479	041 681

i Further versions on request



Voltage

Non-standard voltages

Dimensions [mm]

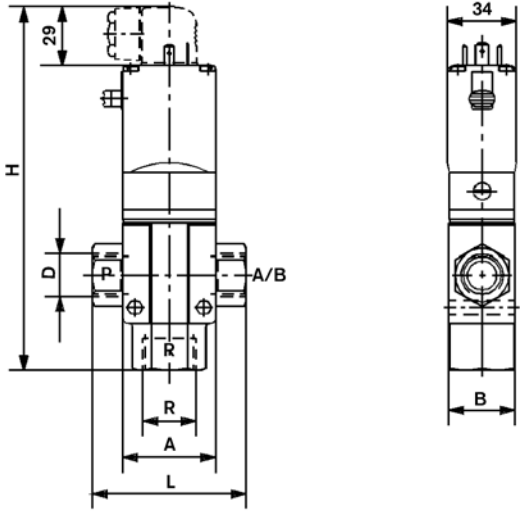

DN	A	B	D	H	L	R
8	46	33	G 1/4	154.5	65	G 3/8
12	46	33	G 3/8	179.5	76	G 3/4
12	46	33	G 1/2	179.5	76	G 3/4
20	62	52	G 3/4	215.5	90	G 1
25	82	60	G 1	237.5	110	G 1 1/4
40	117	88	G 1 1/2	274.0	153	G 2

This dimensional drawing shows a valve in circuit function C with the port specifications P, R and A/B (manual override via port P). In circuit function D the manual override is located above the port A/B (pilot rotated 180° compared to circuit function C). (Vacuum pump connected at port R, atmospheric pressure connected at port P)

To find your nearest Bürkert facility, click on the orange box → www.burkert.com

In case of special application conditions, please consult for advice.

We reserve the right to make technical changes without notice.
© Christian Bürkert GmbH & Co. KG

0804/2_EU-en_00891627